

A carbon attached to a benzene ring has special reactivity so it has a special name - the benzyl carbon

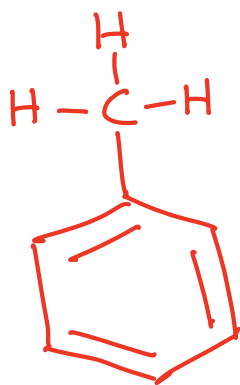

Free radical halogenation

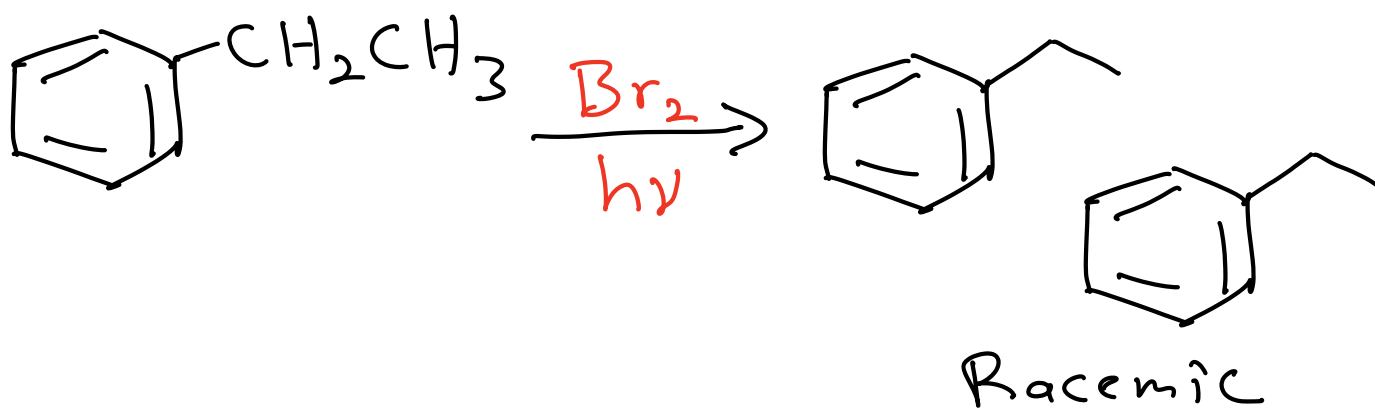

Radical Stability

Methyl $<$ $1^\circ <$ $2^\circ <$ $3^\circ <$ Benzylic Radical

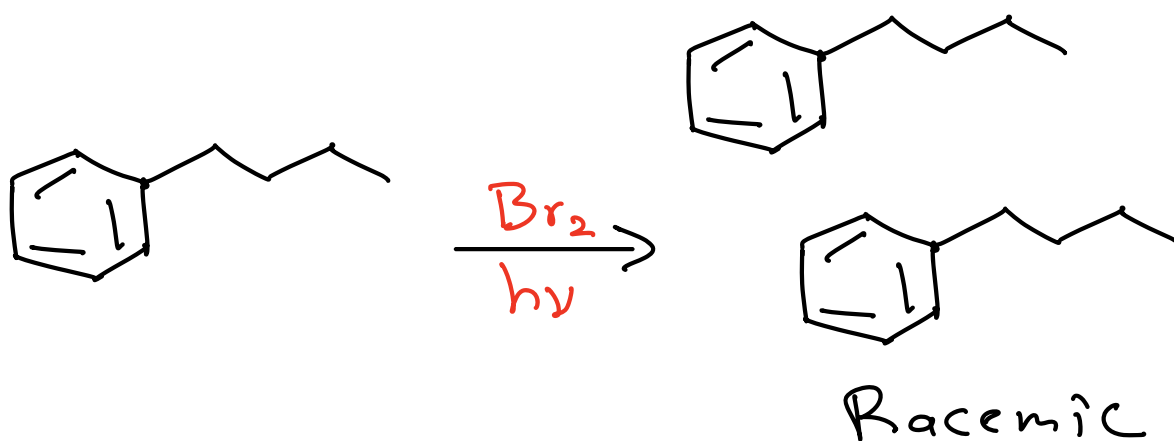

Oxidation

The benzylic carbon is easy to oxidize all the way to a carboxylic acid —

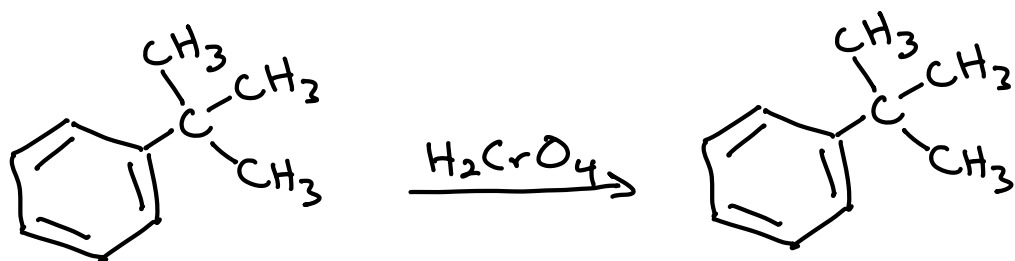
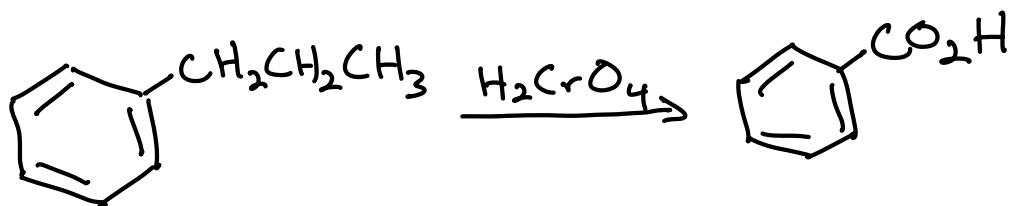
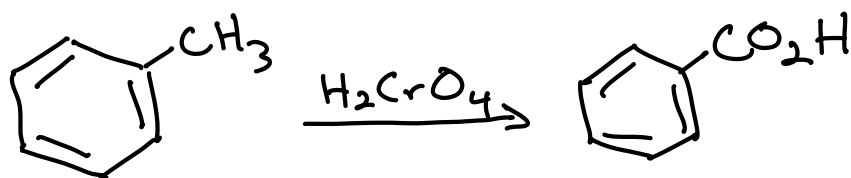

Wicked Strong
Electrophile

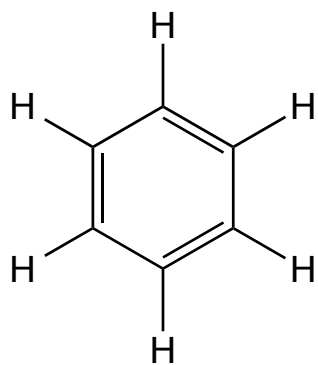

Weak
Nucleophile

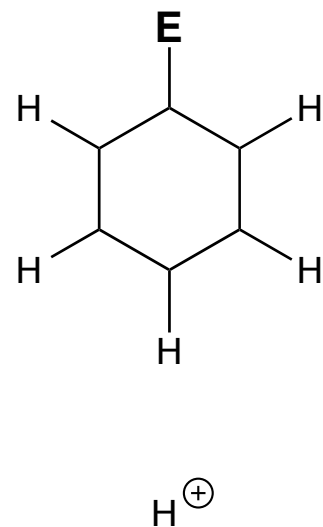
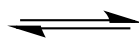
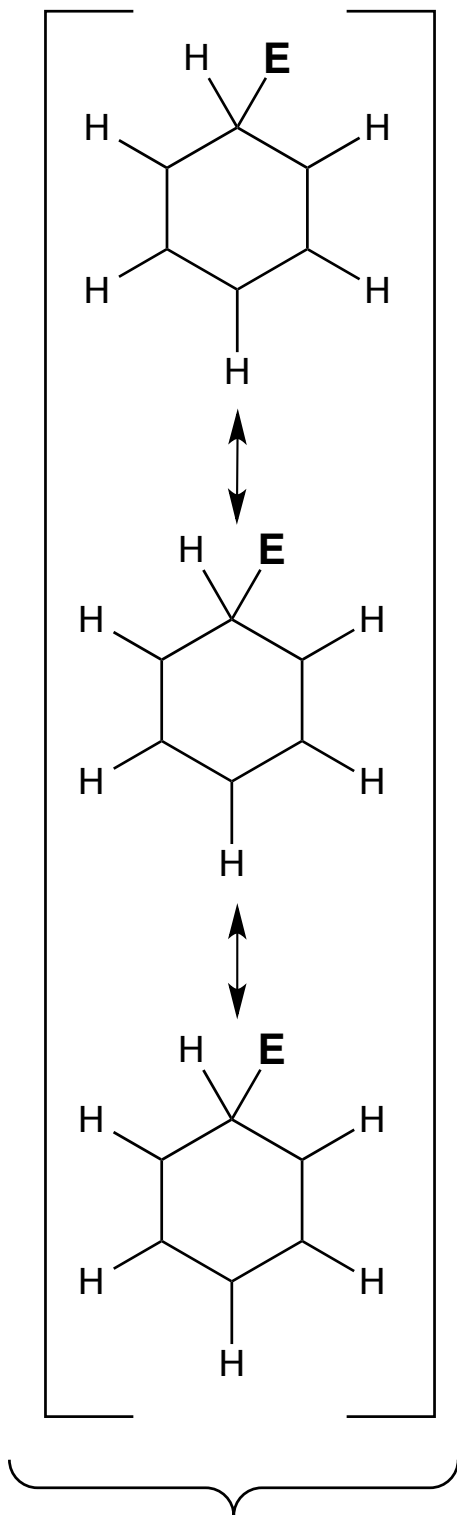
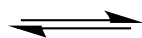

Called the
Arenium Ion

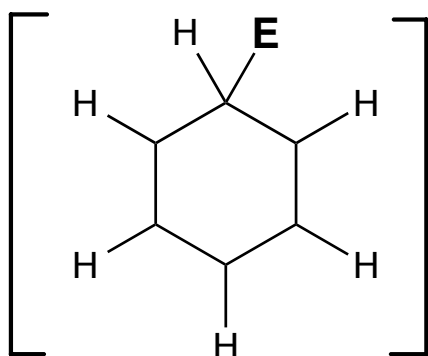

Summary → Wicked strong electrophile reacts with the benzene π electron density to make a resonance delocalized arenium ion intermediate that loses a proton to give a substituted benzene

This reaction is called
"Electrophilic Aromatic Substitution (EAS)"

Reagents

Halogenation X_2, FeX_3

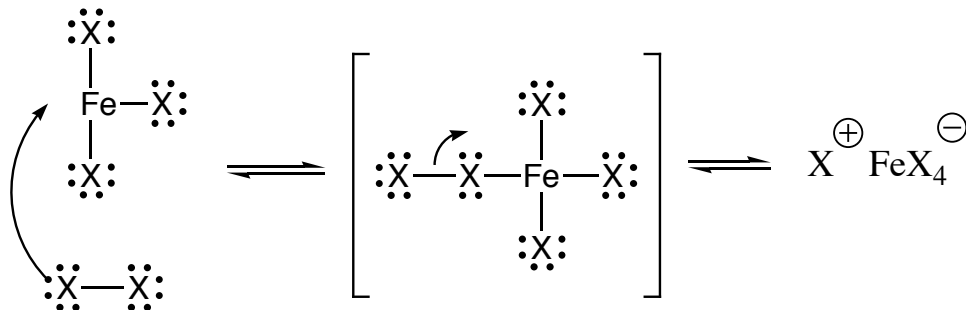

$X = Br, Cl$

Wicked strong
electrophile

E^+

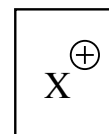

Nitration H_2SO_4/HNO_3

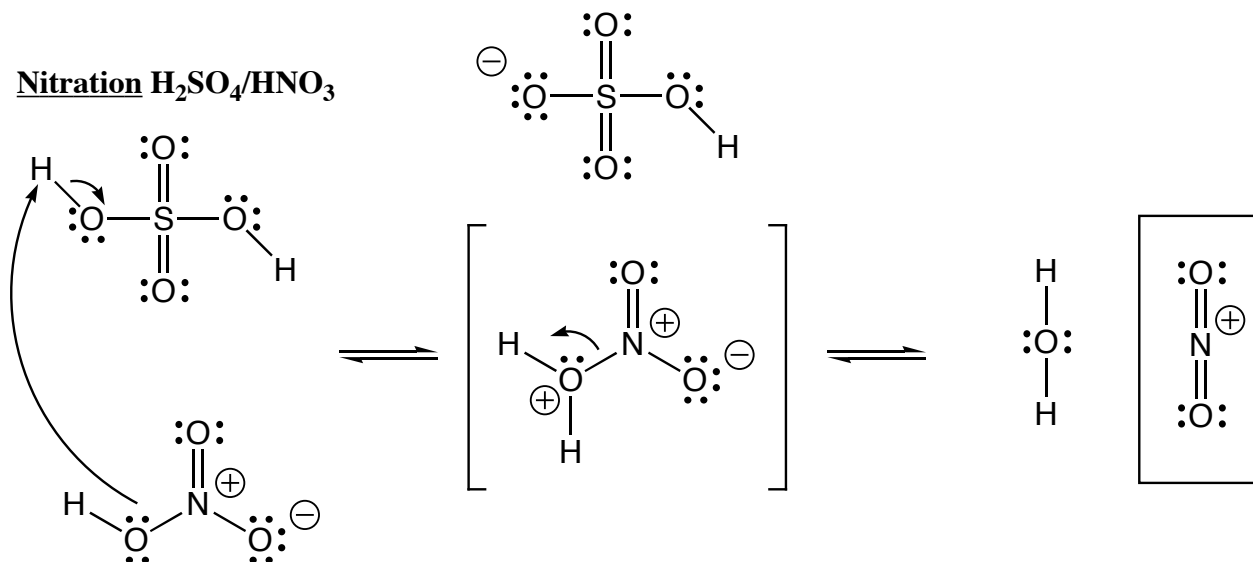

Sulfonation H_2SO_4/SO_3

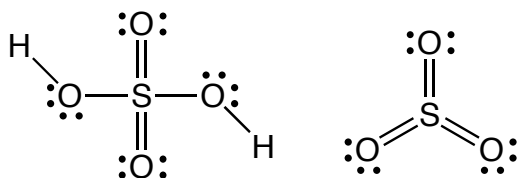

Fuming sulfuric acid
contains both of the
above reagents, the SO_3
is the important one

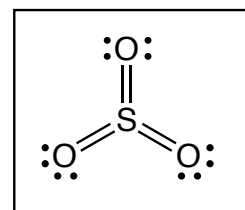

Reagents

Friedel-Crafts Alkylation $R-X, AlX_3$

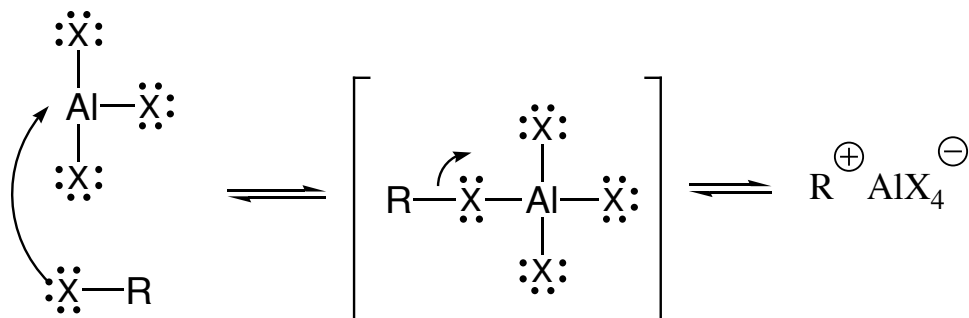

$X = Br, Cl$

Wicked strong electrophile

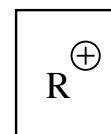

Note this is a carbocation, so it will rearrange if it is a primary or a rearrangement-prone secondary cation

Friedel-Crafts Acylation $RCOCl, AlCl_3$

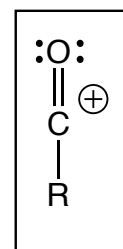
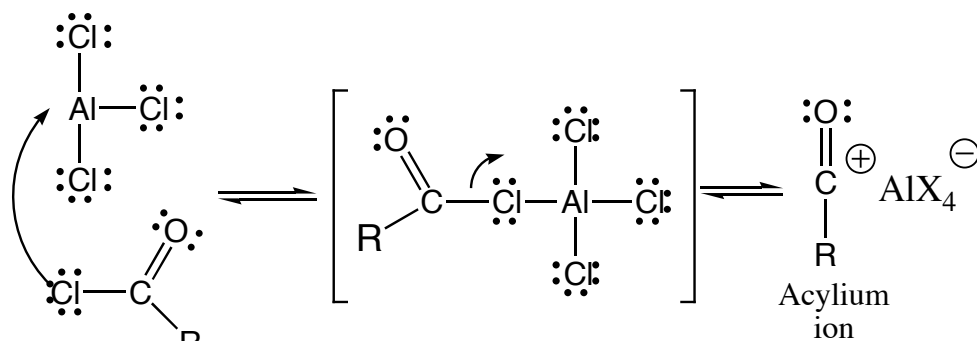

Other notes: 1) It is hard to stop the Friedel-Crafts alkylation after one alkyl group adds (because alkyl groups are "good", that is, activating), but it can be done. 2) Neither Friedel-Crafts reaction works if there is already an electron withdrawing (bad) group on the ring.

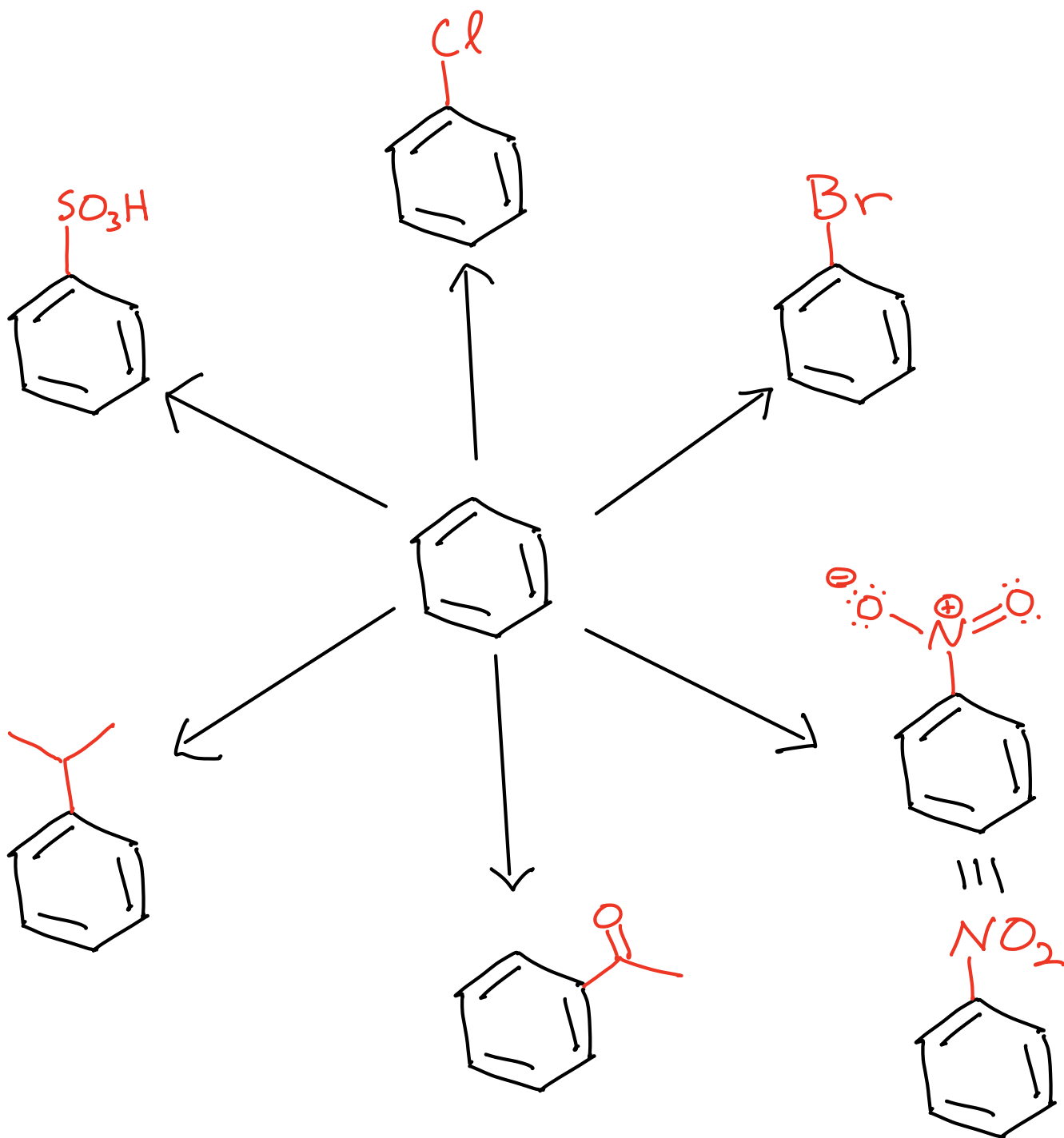

Friedel-Crafts Alkylations

Issue #1 →

Cannot use primary haloalkanes -

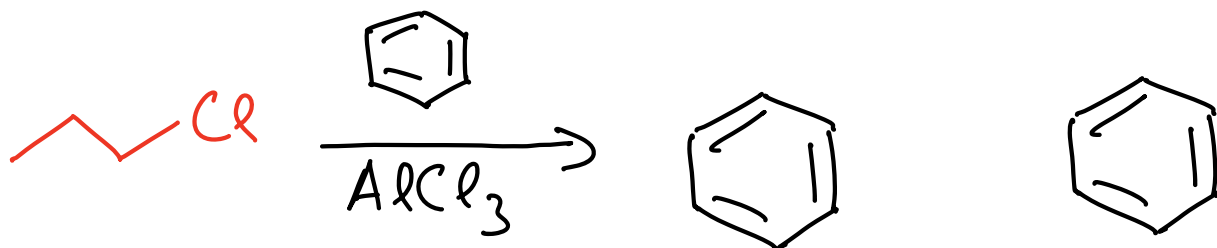
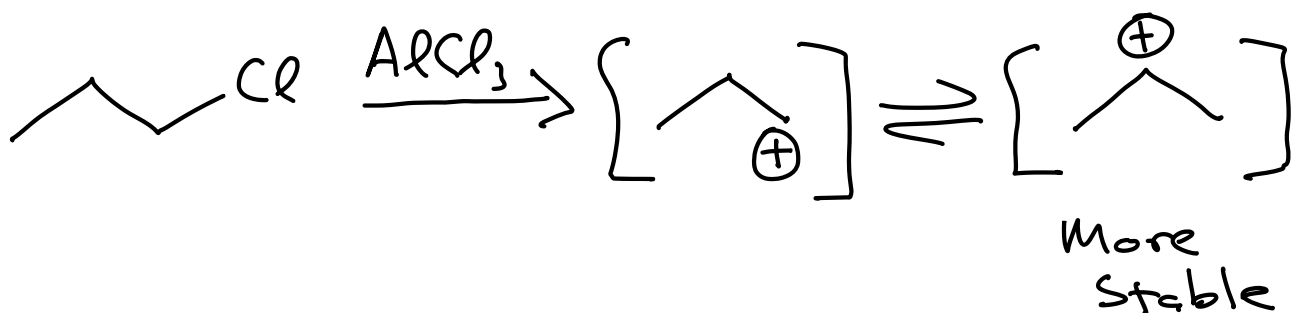

Workaround for primary alkyl group

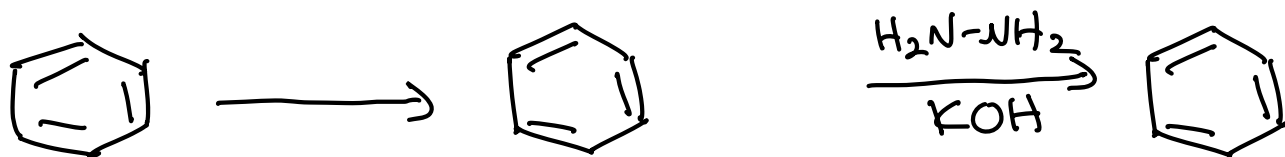

* Acylium ions do NOT rearrange!

Issue #2 → Time capsule: Alkyl groups are GOOD groups,

Issue #3 → Time capsule: Neither the Friedel-Crafts alkylation or acylation will work if

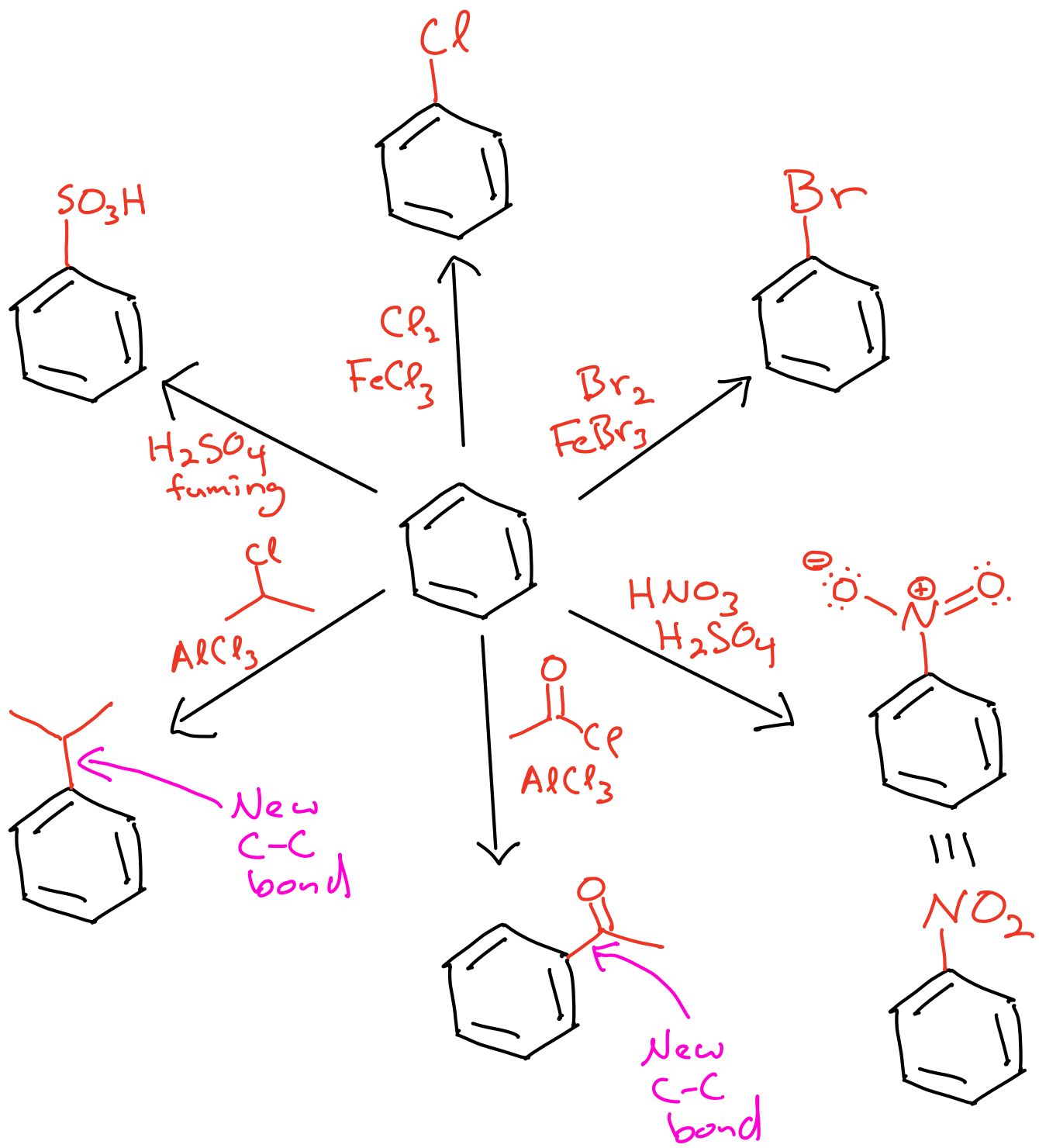

Wicked Strong Electrophile

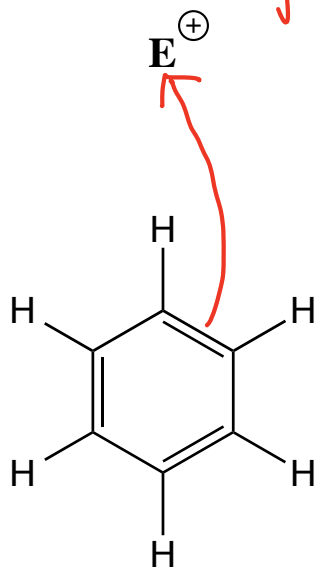

Weak Nucleophile

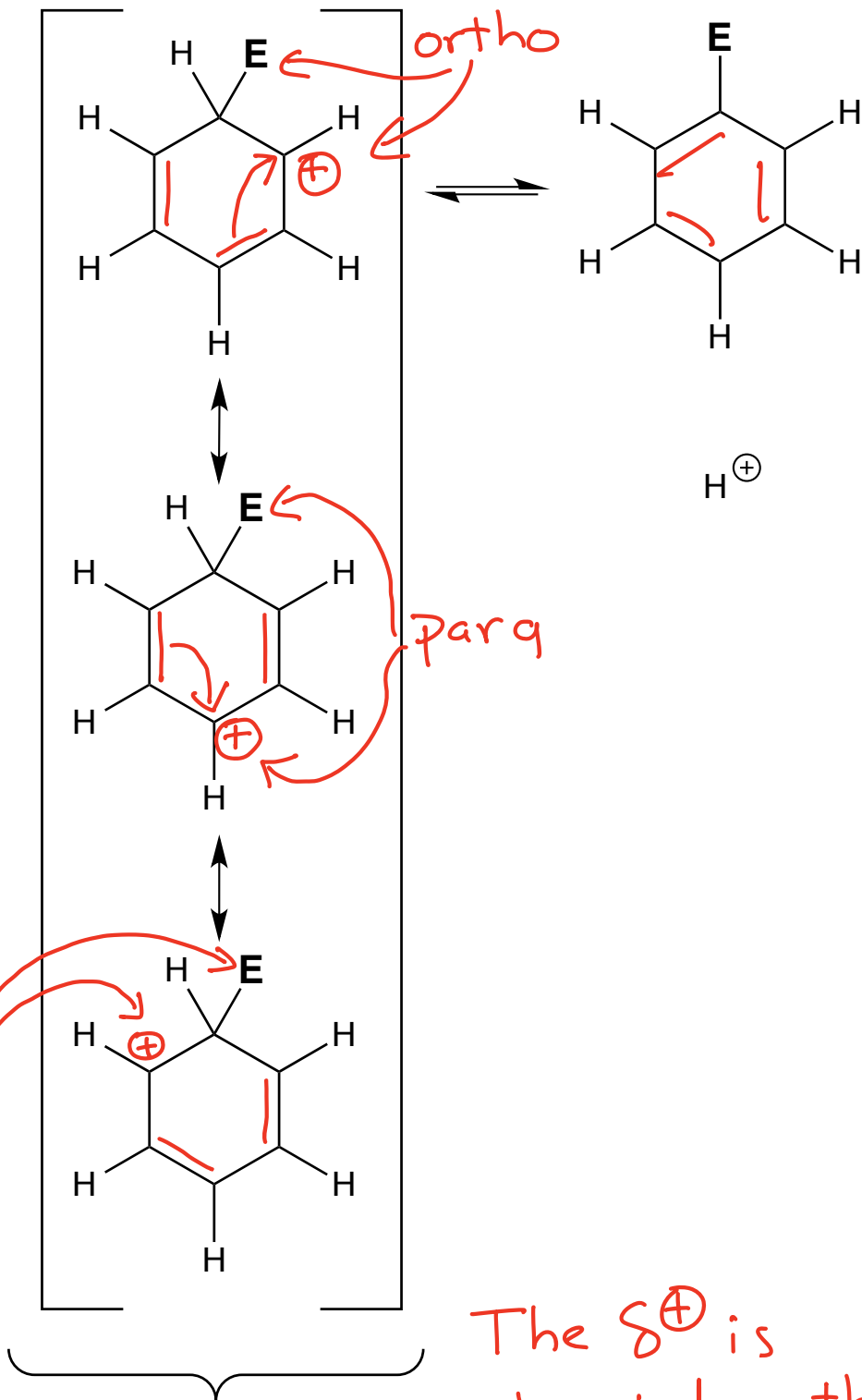
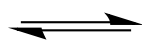

Called the Arenium Ion

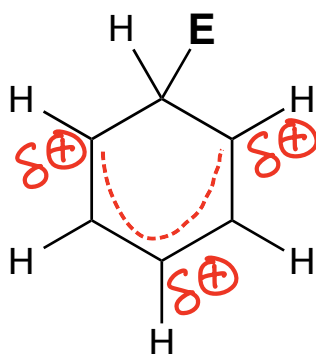

The δ^+ is located ortho and para to where the new bond to "E" is located

Arenium ion *stabilizing* interactions

A) **Pi donation**, a resonance effect for atoms with lone pairs attached to the ring

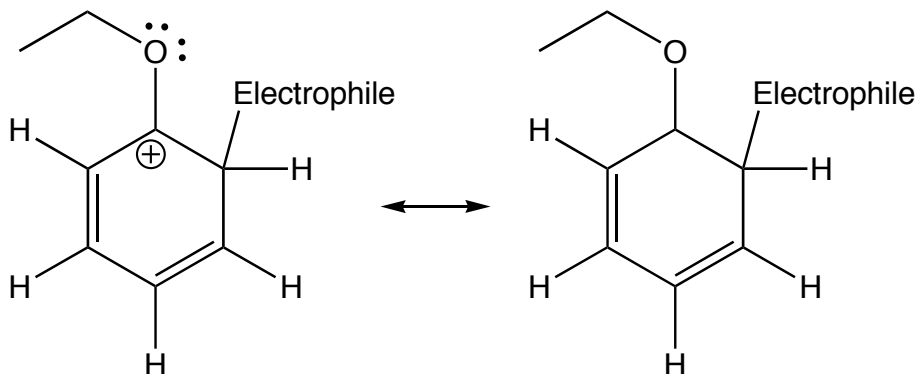

B) **Hyperconjugation** for alkyl groups attached to the ring

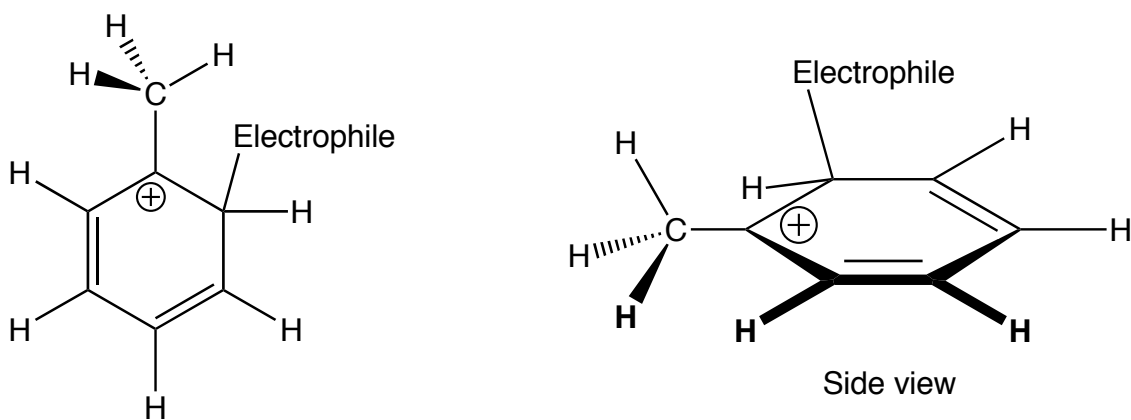

Arenium ion *destabilizing* interaction

A) **Inductive effect** of electronegative atoms or groups attached to the ring

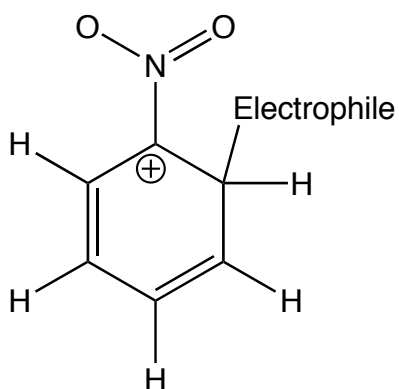

GOOD \rightarrow Through π donation
or hyperconjugation
the arenium ion
is stabilized

BAD \rightarrow Through the
inductive effect -
electron withdrawing
groups - the arenium
ion is destabilized

UGLY

→ Both GOOD and BAD
at the same time

→ Through π donation
or hyperconjugation
the arenium ion
is stabilized

→ Through the
inductive effect -
electron withdrawing
groups - the arenium
ion is destabilized

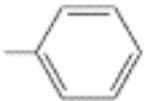
Ortho-Para Directing	Strongly activating	$-\ddot{\text{N}}\text{H}_2$	$-\ddot{\text{N}}\text{HR}$	$-\ddot{\text{N}}\text{R}_2$	$-\ddot{\text{O}}\text{H}$	$-\ddot{\text{O}}\text{R}$	GOOD	↑ Relative importance in directing further substitution	
	Moderately activating	$-\ddot{\text{N}}\text{H}\overset{\text{O}}{\parallel}\text{CR}$	$-\ddot{\text{N}}\text{H}\overset{\text{O}}{\parallel}\text{CAr}$	$-\ddot{\text{O}}\overset{\text{O}}{\parallel}\text{CR}$	$-\ddot{\text{O}}\overset{\text{O}}{\parallel}\text{CAr}$				
	Weakly activating	$-\text{R}$							
	Weakly deactivating	$-\ddot{\text{F}}:$	$-\ddot{\text{Cl}}:$	$-\ddot{\text{Br}}:$	$-\ddot{\text{I}}:$				UGLY
Meta Directing	Moderately deactivating	$-\overset{\text{O}}{\parallel}\text{CH}$	$-\overset{\text{O}}{\parallel}\text{CR}$	$-\overset{\text{O}}{\parallel}\text{COH}$	$-\overset{\text{O}}{\parallel}\text{COR}$	$-\overset{\text{O}}{\parallel}\text{CNH}_2$	$-\overset{\text{O}}{\parallel}\text{SOH}$	$-\text{C}\equiv\text{N}$	
	Strongly deactivating	$-\text{NO}_2$	$-\text{NH}_3^+$	$-\text{CF}_3$	$-\text{CCl}_3$			BAD	

ORTHO

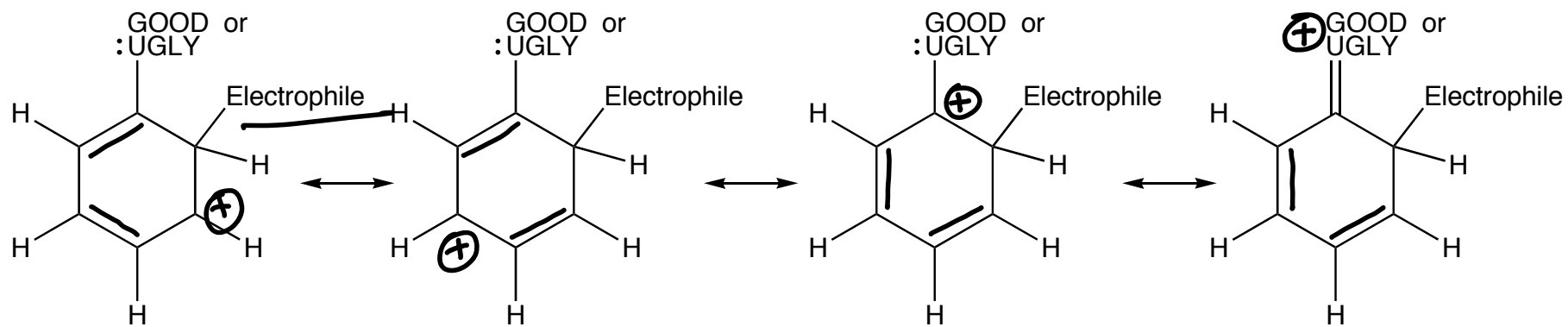

META

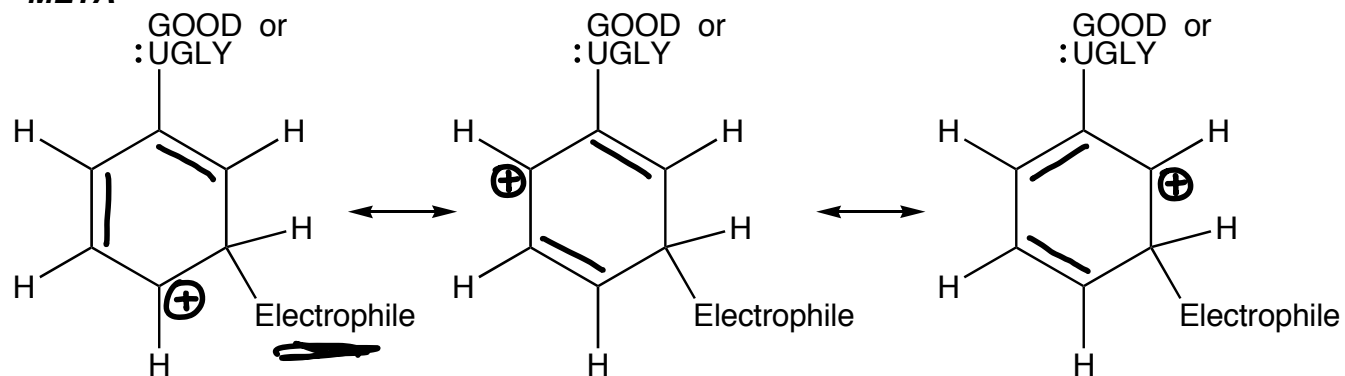

PARA

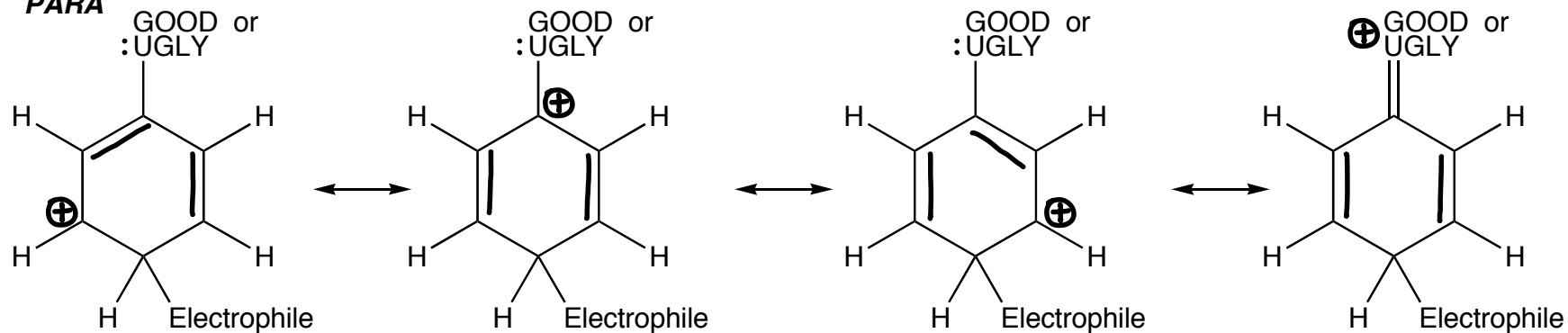

ORTHO

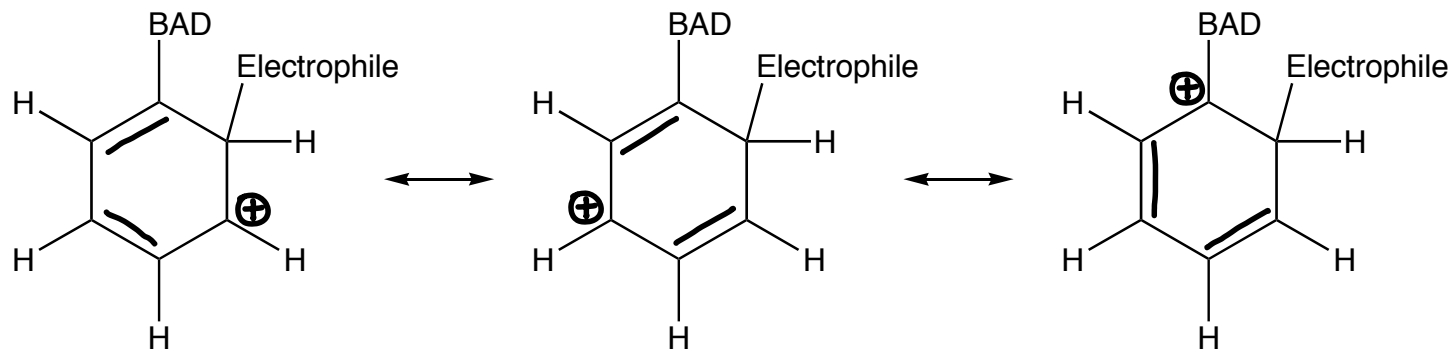

META

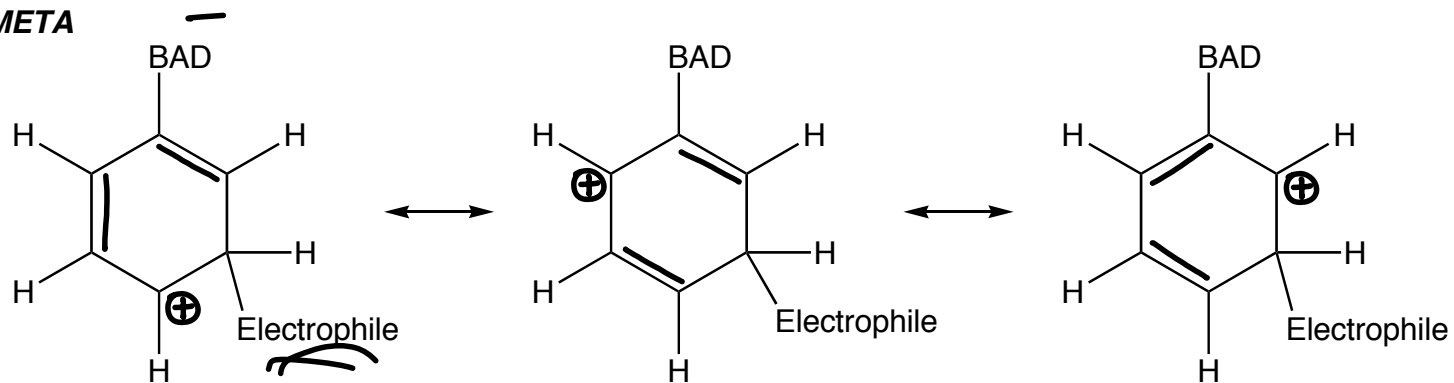

PARA

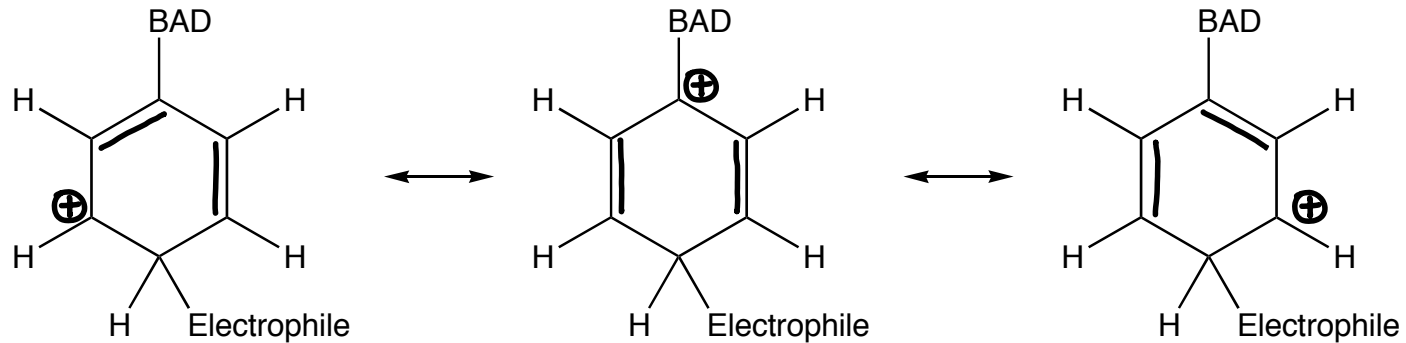

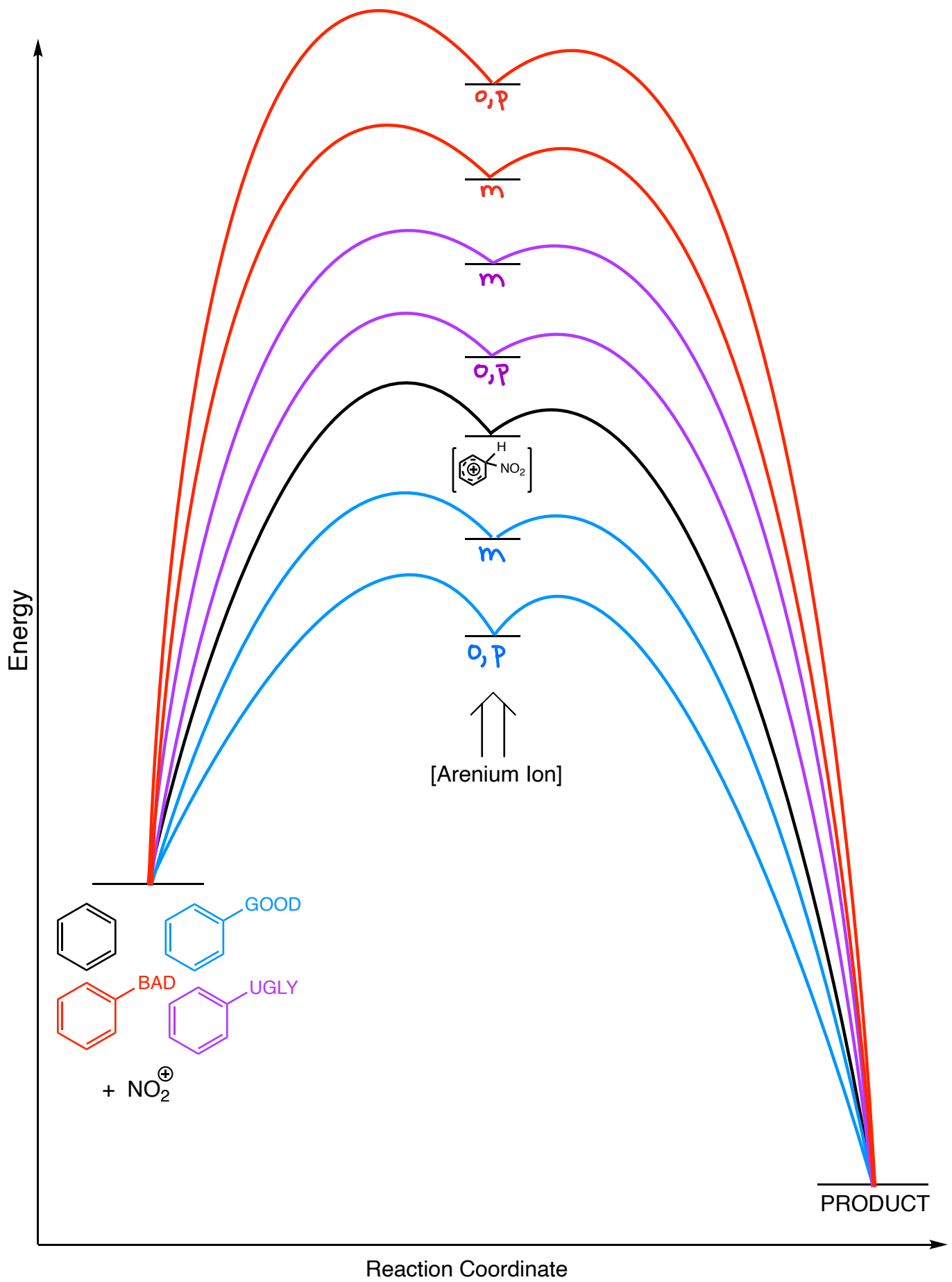

Examples

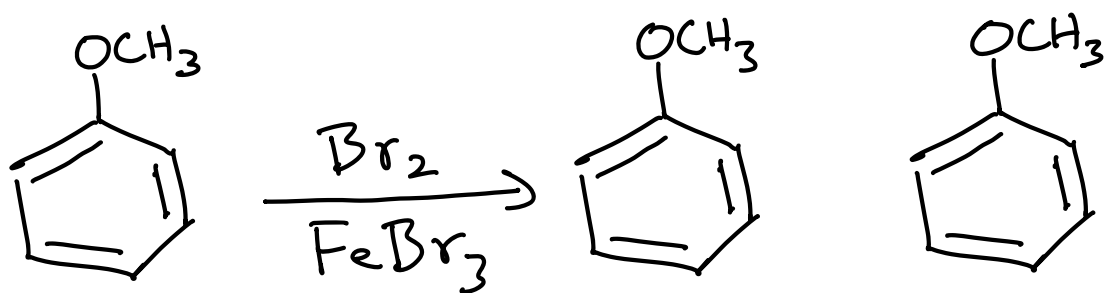
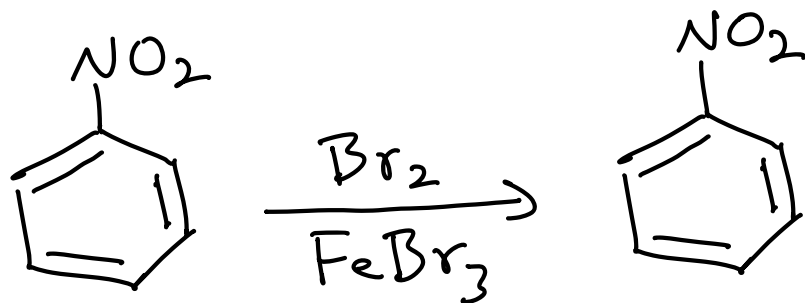

The order in which you add groups matters!

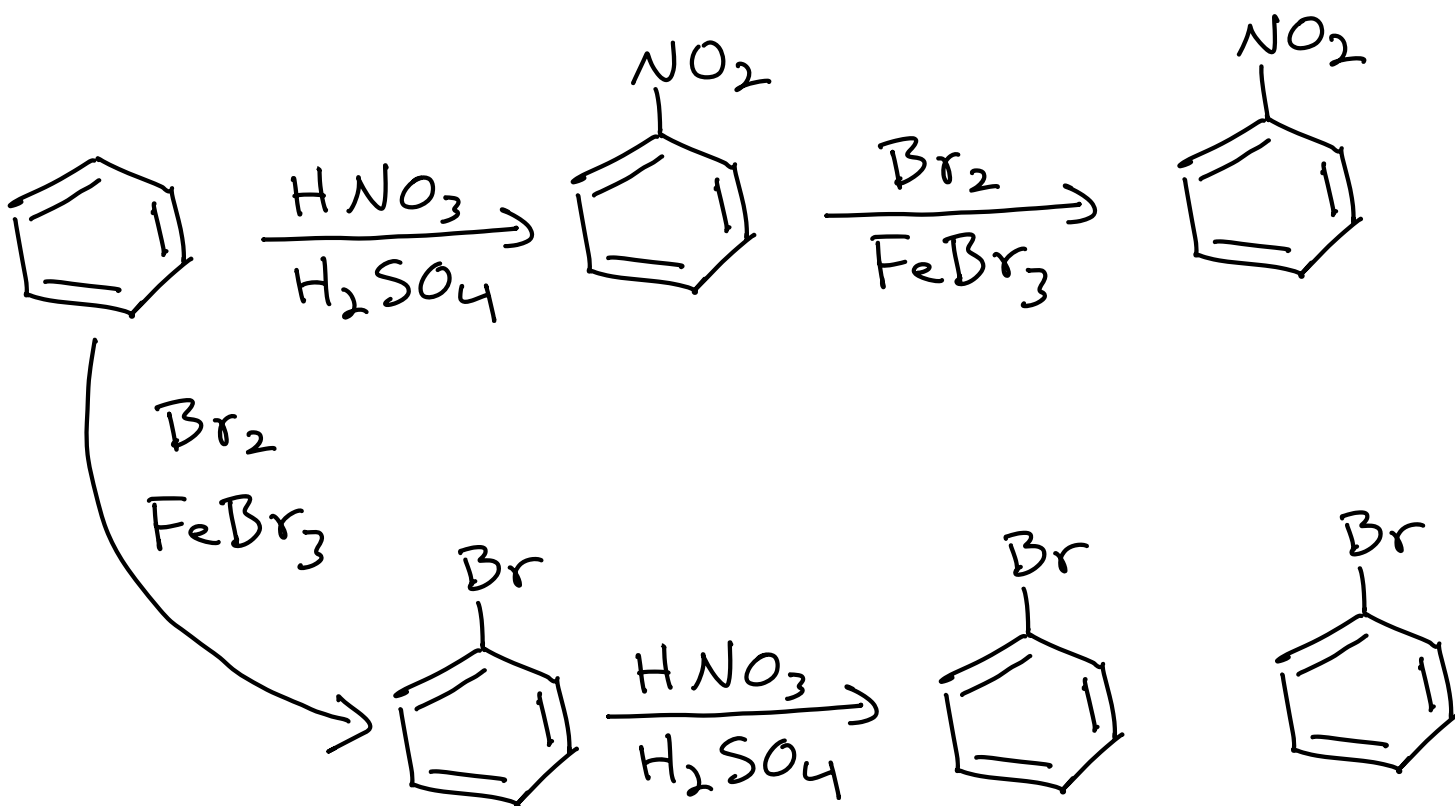



What if there are two groups already on the ring and they predict different products?

It is a duel \rightarrow the movie got it right!

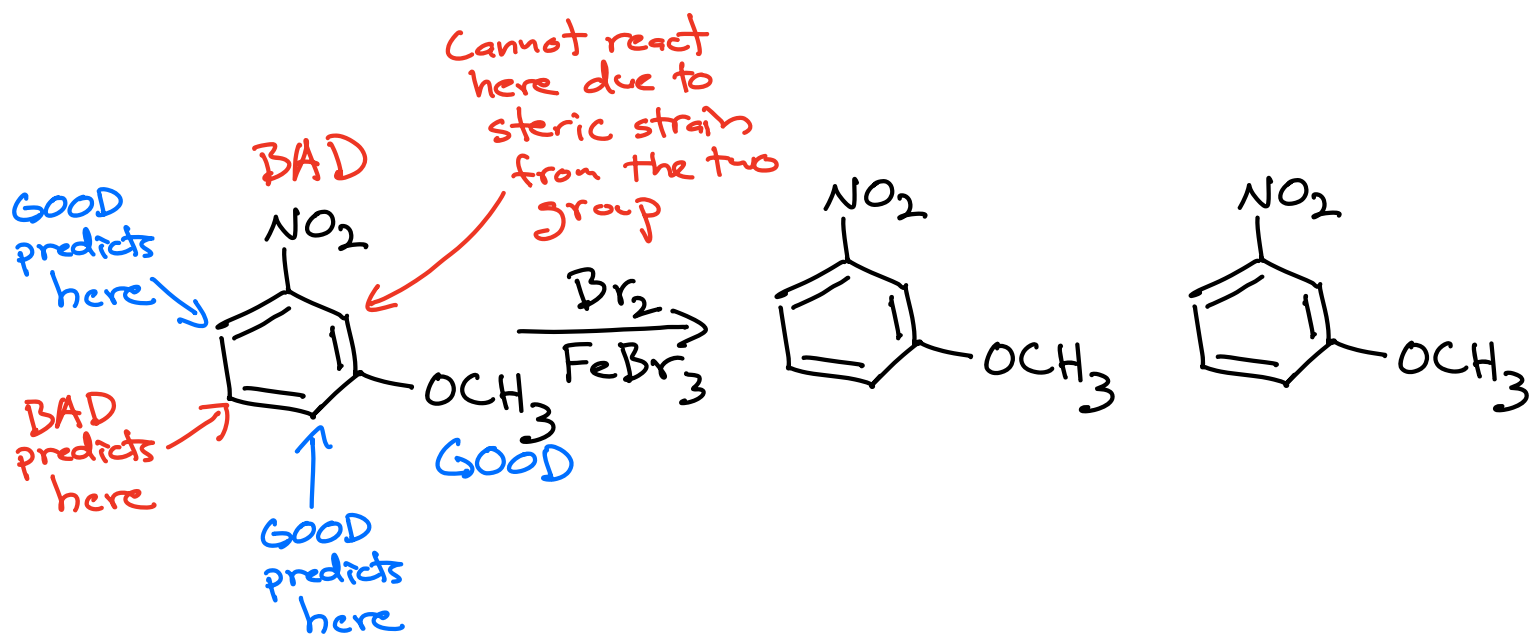

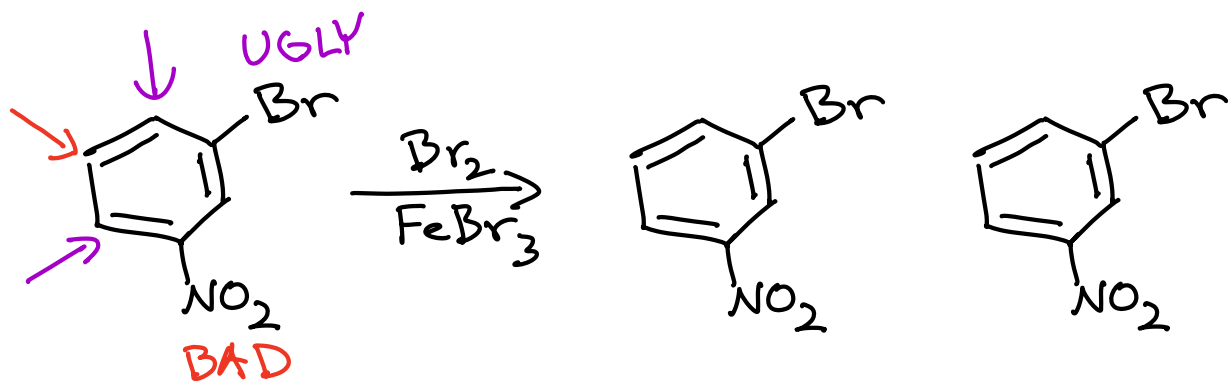

Sometimes two groups will predict the same outcome

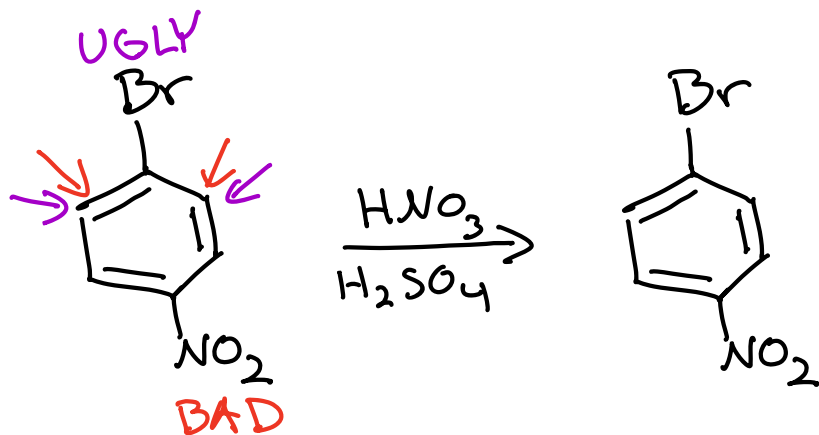

Classic Question

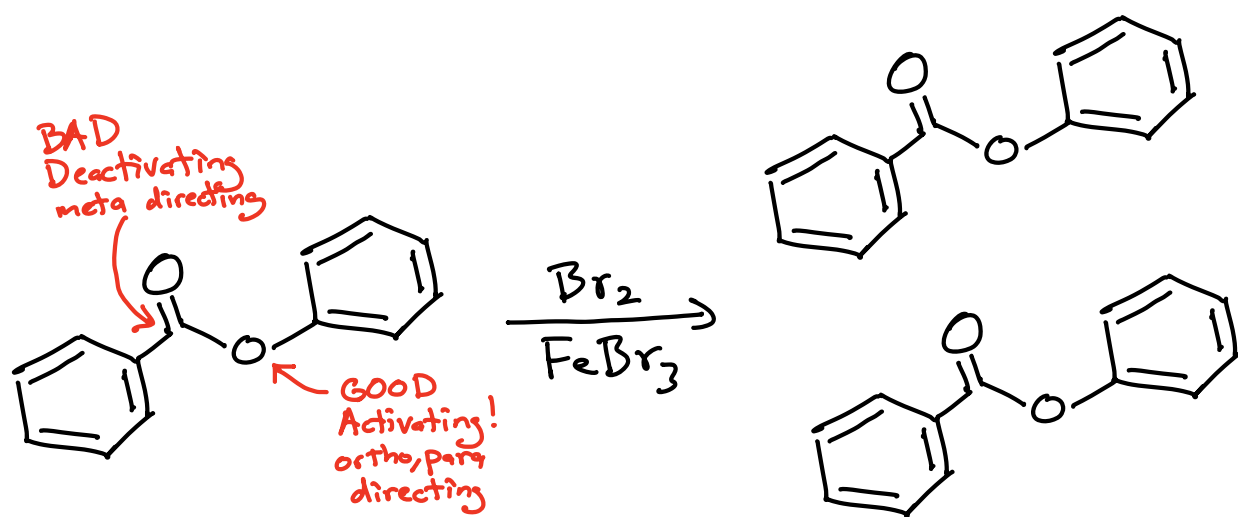

Amines \rightarrow Relatively strong bases
and relatively strong
nucleophiles

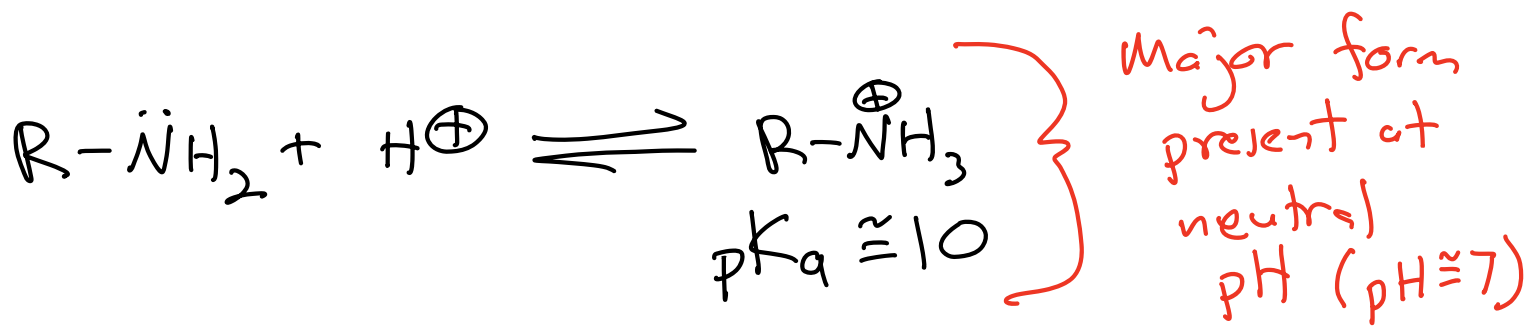

Amines are protonated and positively-charged at neutral pH \Rightarrow Very important in biochemistry!

Amino Acids

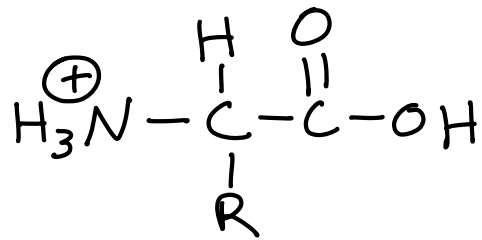

pH 1.0

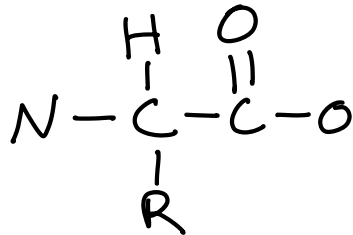

pH 7.0

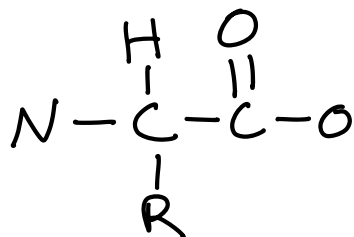

pH 11.0

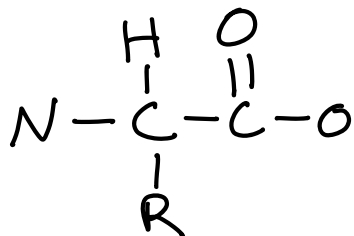

Wikipedia

amino group

carboxyl group

variable side chain

File:Amino acid generic structure.png - Wikipedia

Visit >

ResearchGate

Amino Group

Variant Group

Carboxyl Group

amino acid structure | Download Scientific Diagram

Visit >

user.eng.umd.edu

amino group

side chain

carboxyl group

Protein > Amino Acids

Visit >

Study.com

R

α

Proteins & Amino Acids | Formation, Structures & Sources - Lesson | Study.com

Visit >



What does this mean for amides:

- 1) The amide group can make strong hydrogen bonds
- 2) The C-N bond **does not rotate** at room temperature

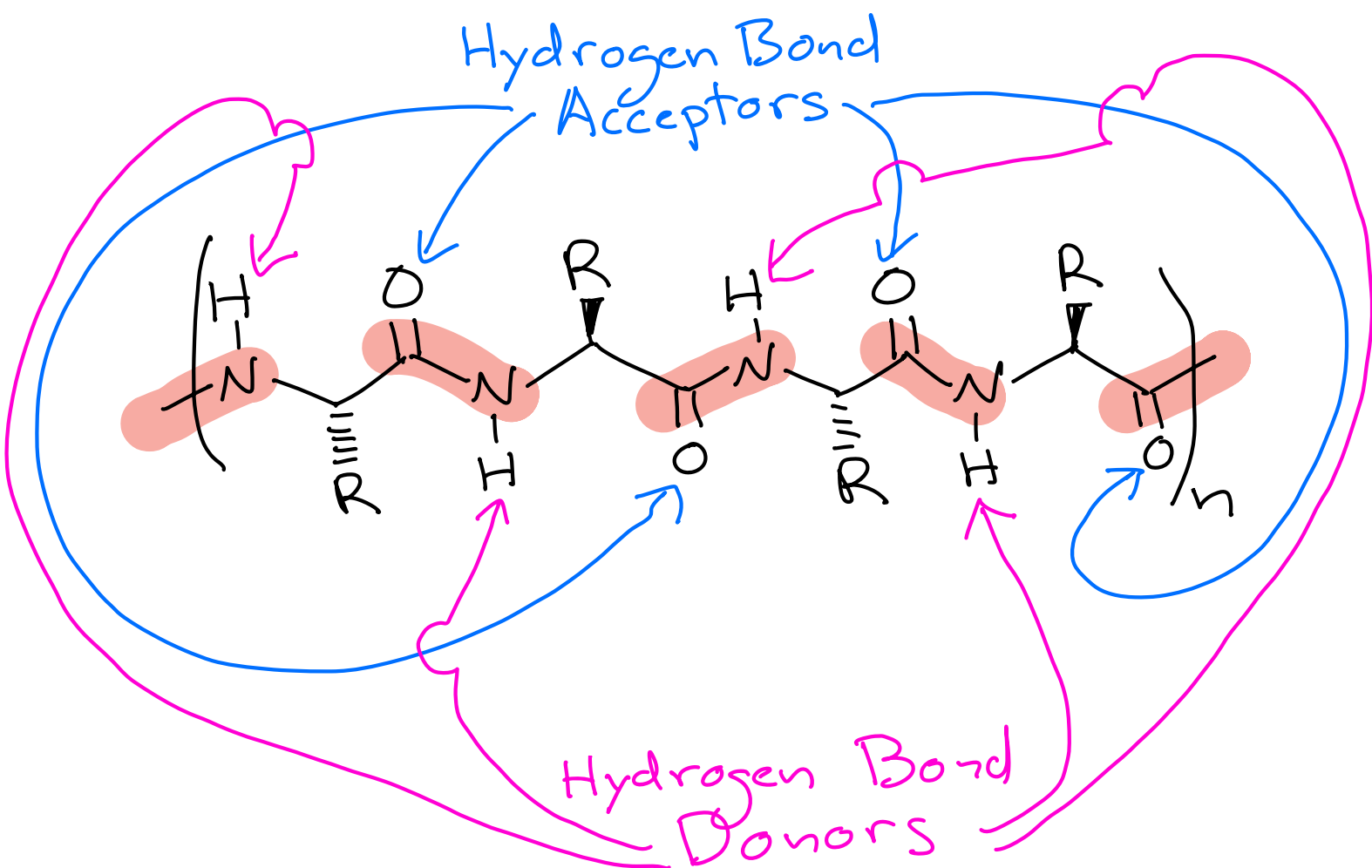

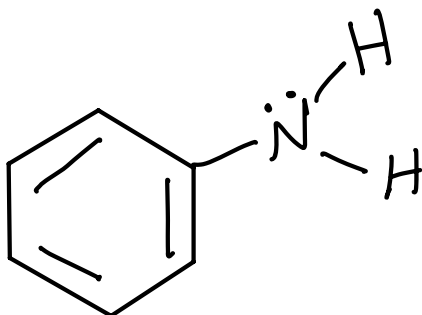
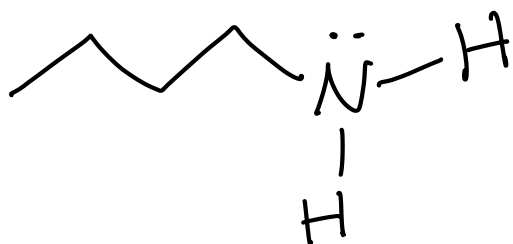

Golden rule:
π electrons
are more
stable when
delocalized

This is critical to DNA and RNA structure: DNA bases are aromatic and the $-NH_2$ groups on the bases are

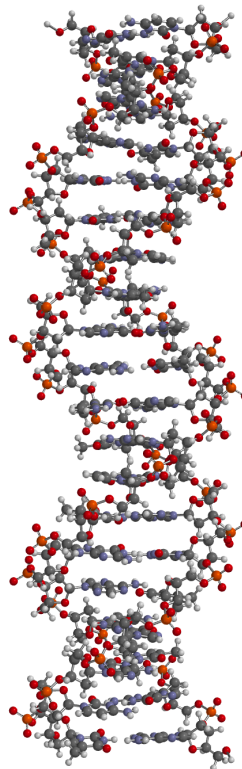
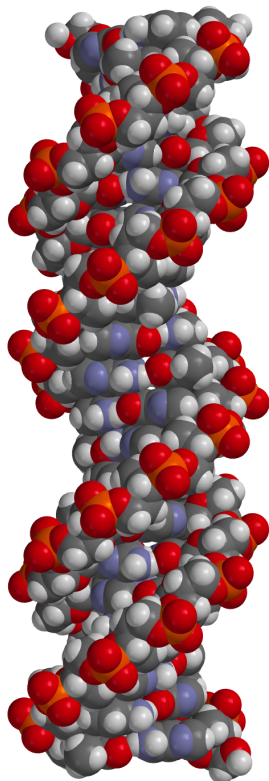
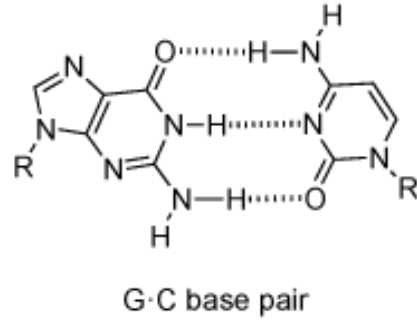
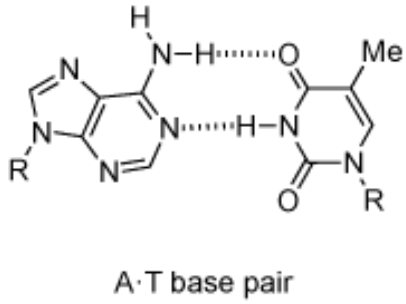
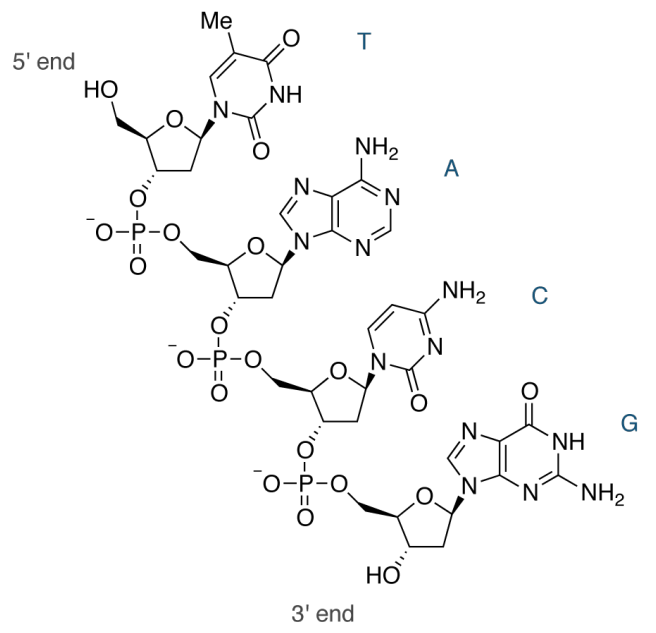
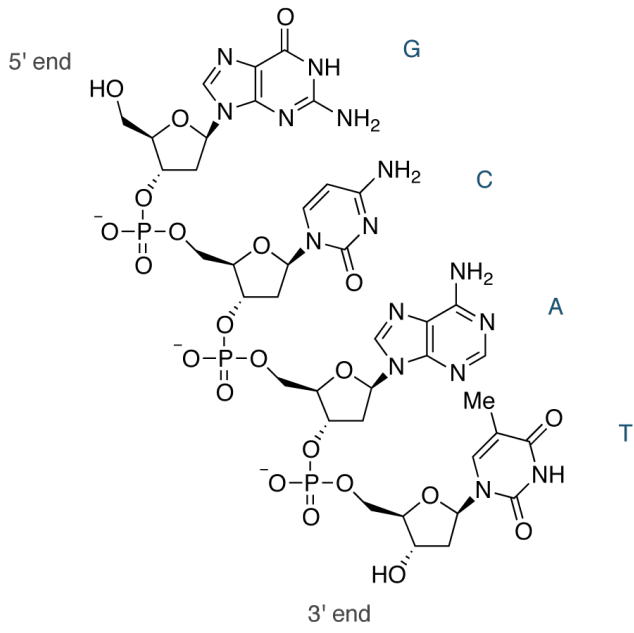

Our sense of smell is highly sensitive to certain molecules that are the result of decomposition of mammal and fish flesh among other things. Not only can we detect very small amounts of these "signal" molecules, we are hard wired to be highly nauseated when we smell them → evolutionary protection to keep us from eating what might look OK, yet would make us sick.

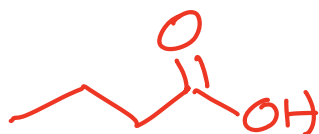
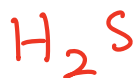
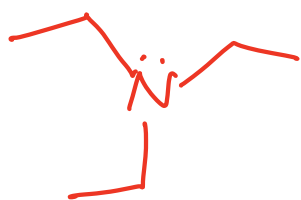

The order in which you add groups matters!

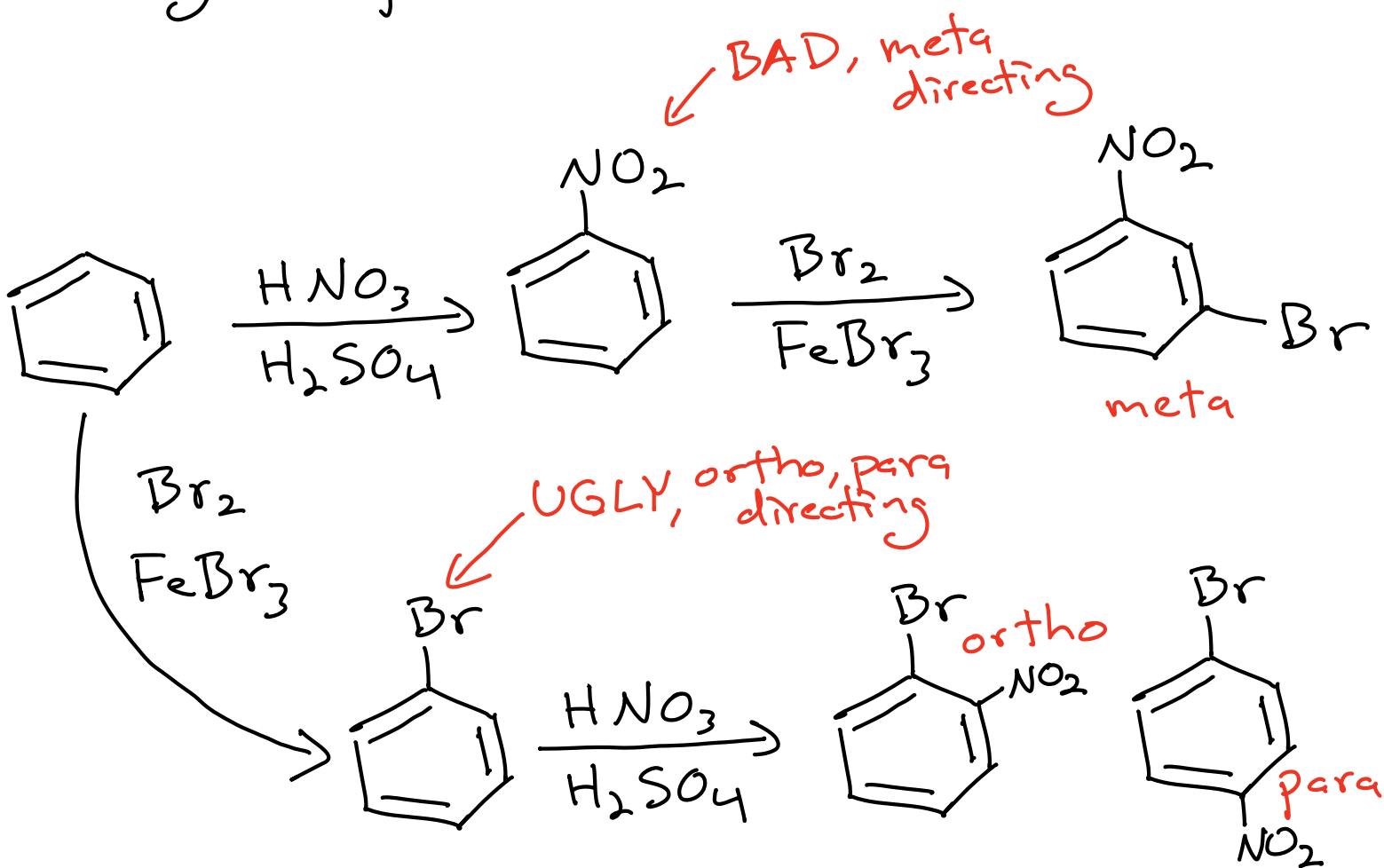

How do we carry out the following synthesis?

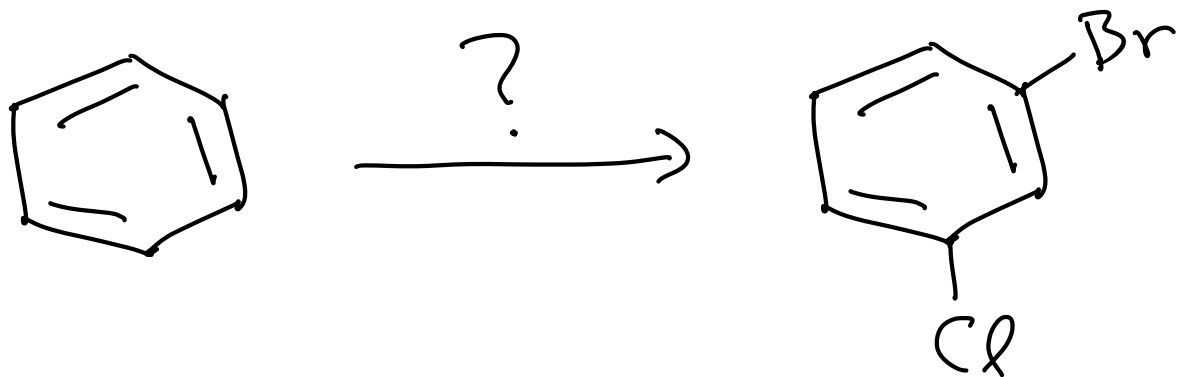

Preparation of Diazoniums, The "Mr. Bill" Reaction

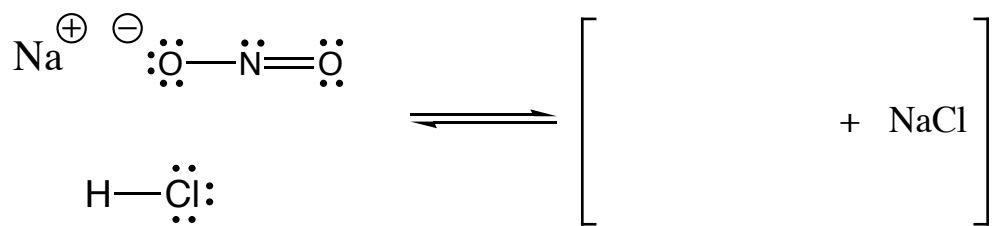

The Mr. Bill reagent

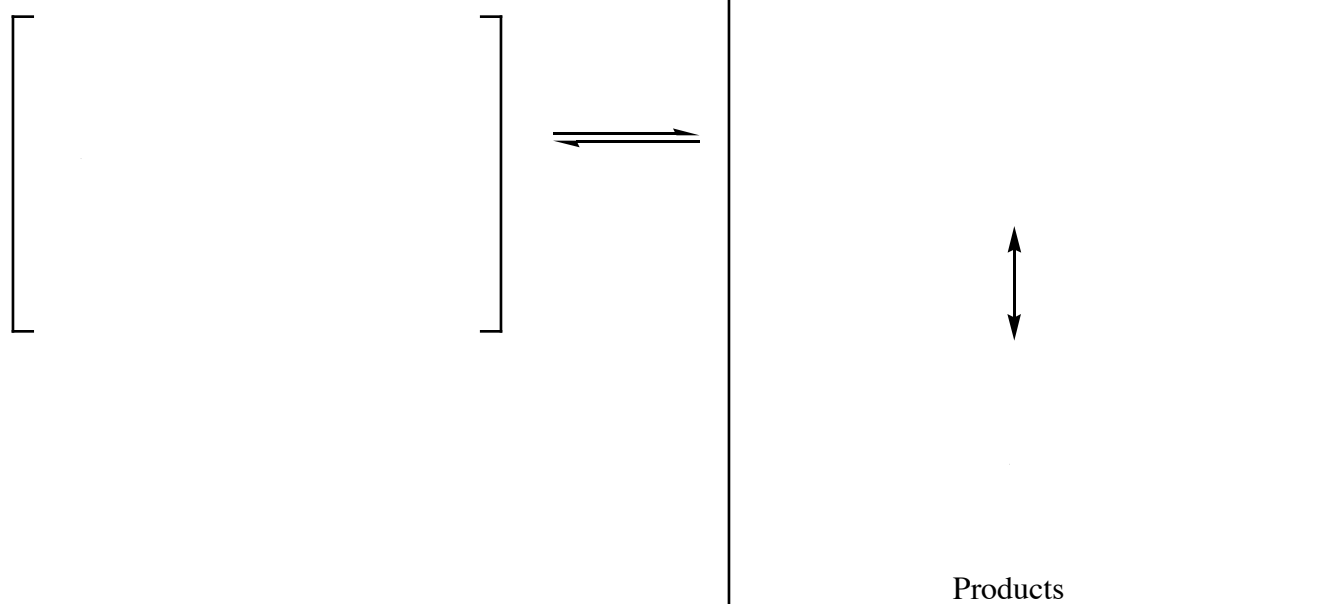
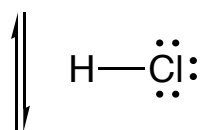
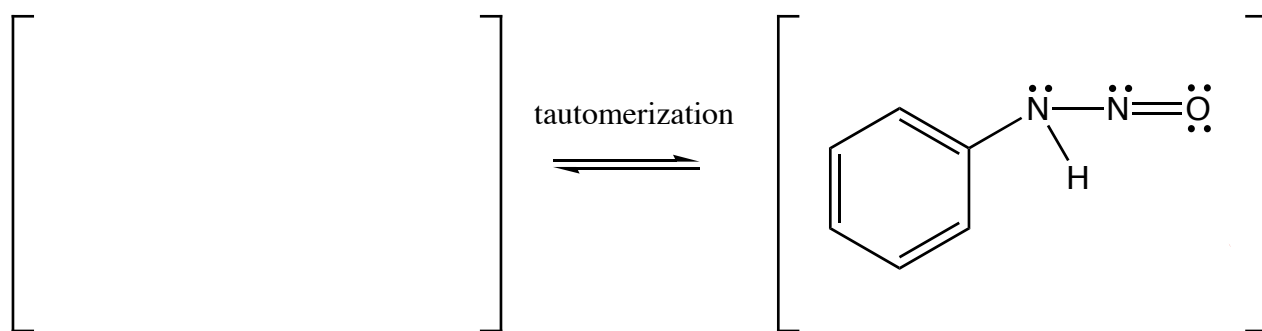
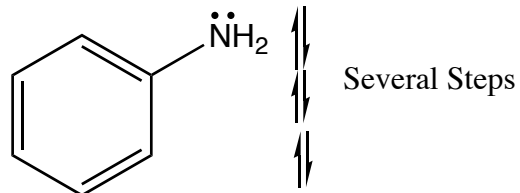

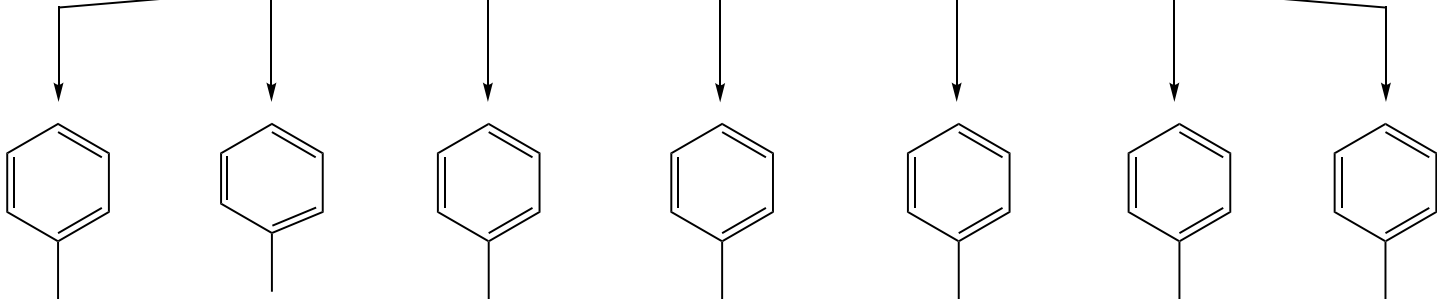
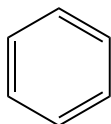
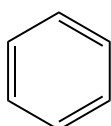
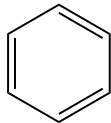
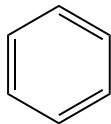

Sandmeyer Reaction

How do we carry out the following synthesis?

